

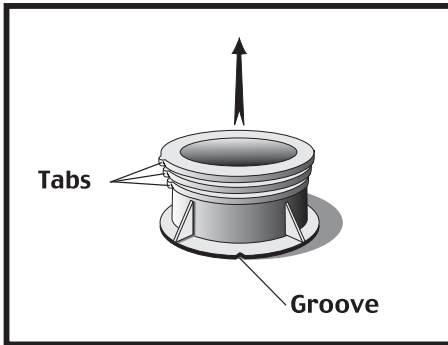

Terr-Adjust Instructions

PATENT 4,570,397



1. Line up tabs with groove at base of unit. Pull up on top ring to bring unit to a point higher than required by project.

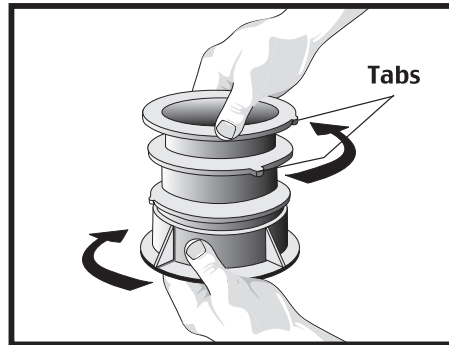

2. Lock pedestal by twisting the unit 1/8 to 1/4 turn in either direction.

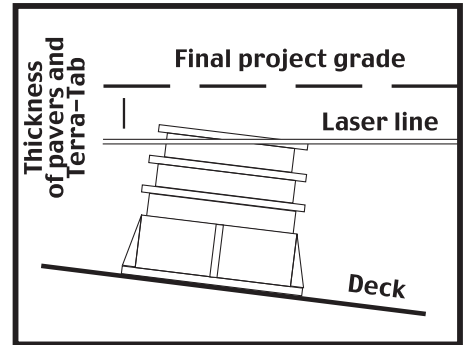

3. Use a Laser Line (or equivalent) to establish final project grade. Subtract thickness of paver and support unit (Terra-Tab) to determine final Terr-Adjust height.

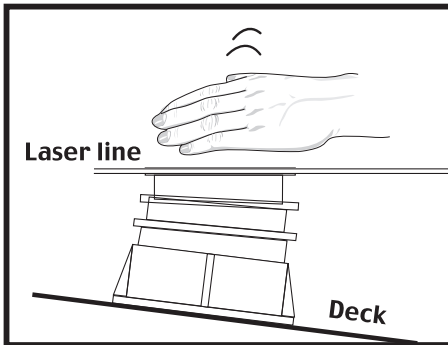

4. Tap the pedestal to bring it level with established Laser Line.

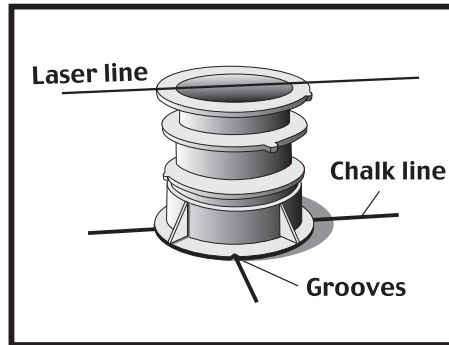

5. Slide adjusted pedestal under laser line placing all four grooves on chalk lines previously established for paver layout.

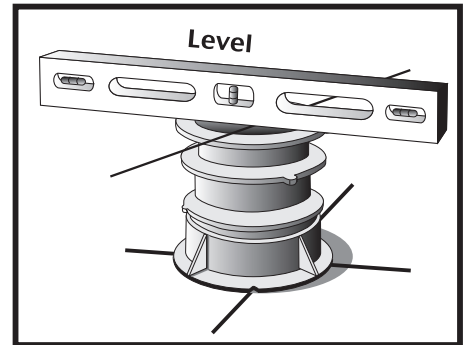

6. Check level of pedestal perpendicular to string and make any necessary adjustments.

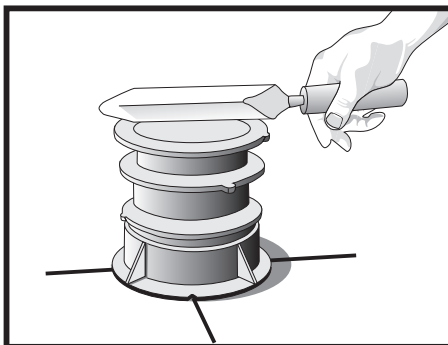

7. Mix Terra System One Mix according to package instructions and fill the unit cavity. Top off the unit with a trowel.

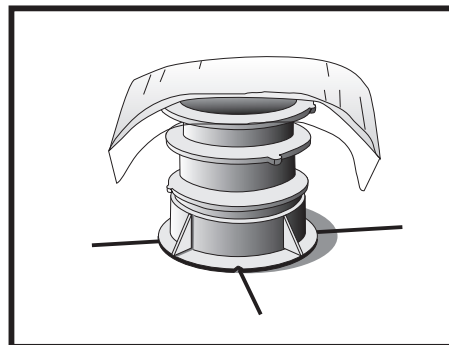

8. Allow Terra System One Mix to cure. If conditions are near freezing, cover the unit with insulation (or equivalent) until mix hardens. Check package instructions.

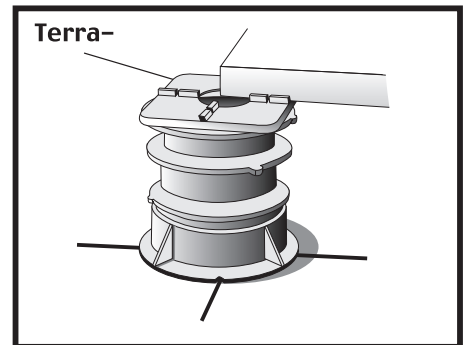

9. When mix is completely cured, place paver support units (Terra-Tabs) and install pavers.

*If more height is required, see step 10 for use of extender.



Terr-Adjust Instructions

PATENT 4,570,397

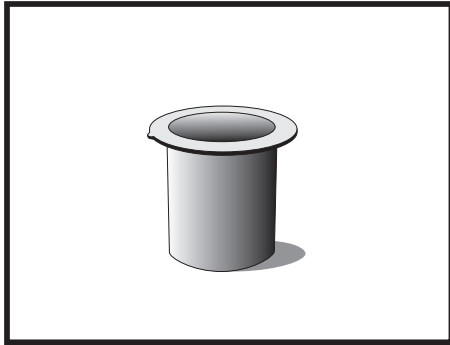

10. Terr-Adjust extenders are to be used when height adjustments from 5 1/2" to 10" are required.

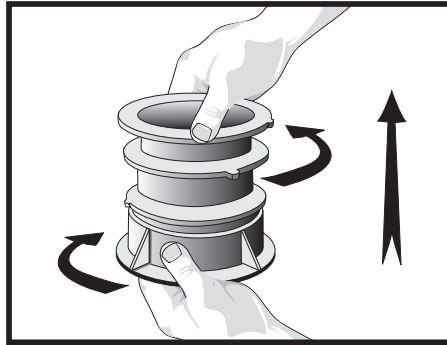

11. Pull up on Terr-Adjust unit to bring to its maximum extension. Lock pedestal by twisting the unit 1/8 to 1/4 turn in either direction.

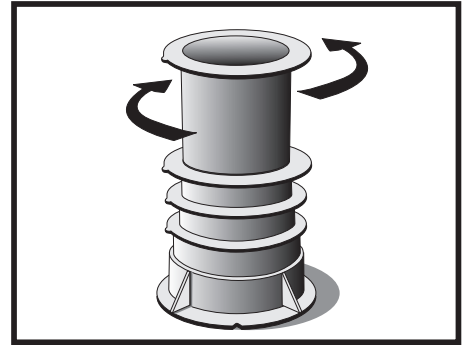

12. Insert extender unit into throat of extended Terr-Adjust. Turn unit 1/8 to 1/4 turn. Lock at a point higher than required. Then return to step 3 for basic instructions.



Division of Wausau Tile, Inc.
P.O. Box 1520
Wausau, WI 54402-1520
1-800-388-8728
1-715-359-3121
1-715-359-7456 FAX
Web: wausautile.com
email: paving@wausautile.com

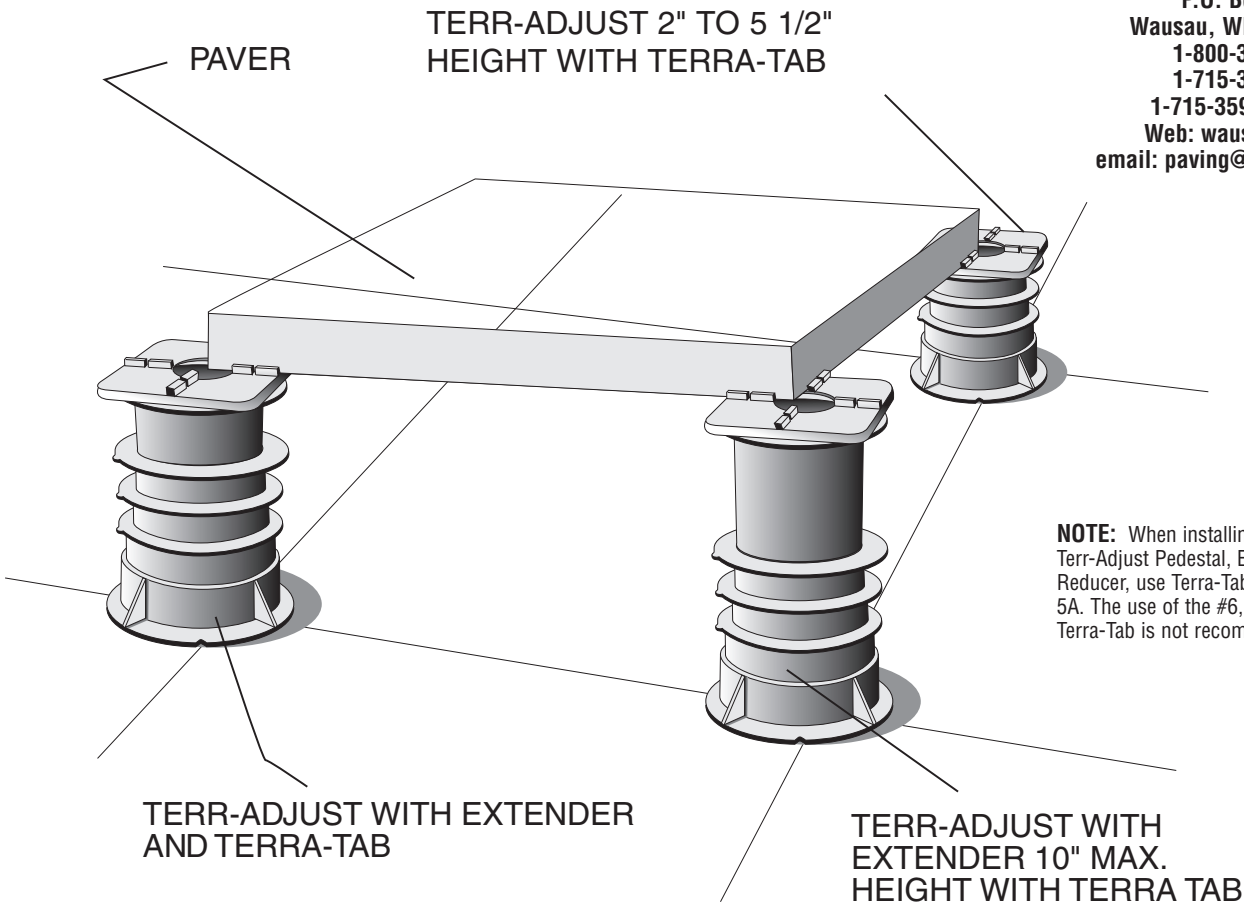

NOTE: When installing with the Terr-Adjust Pedestal, Extender or Reducer, use Terra-Tab sizes #5 or 5A. The use of the #6, 6A or 7 Terra-Tab is not recommended.